

Operation Instructions of full touch DIM wall-panel remote

I. Specifications:

Working temperature: -20-60 °C
 Dimension: L86*W86*H34 mm
 Net weight: 130g

Working voltage: AC90-265V(50/60Hz)
 RF frequency: 2.4GHz
 RF distance: 20m

II. Control Method:

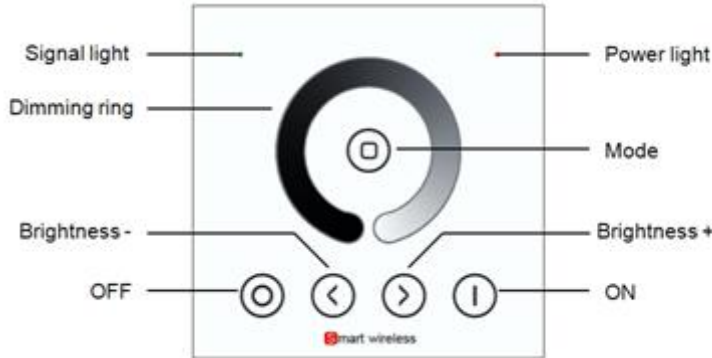

The function of each button as below:

Name of key	Instruction	Remarks
ON	ON in any time	
OFF	OFF in any time	
Mode	Full light hot key	
Brightness +	The brightness will +1, when touch the key each time	Long-press can get fast adjusting.
Brightness -	The brightness will -1, when touch the key each time	Long-press can get fast adjusting.
DIM Ring	Touch any dim	

III .Wall-panel Installation instruction

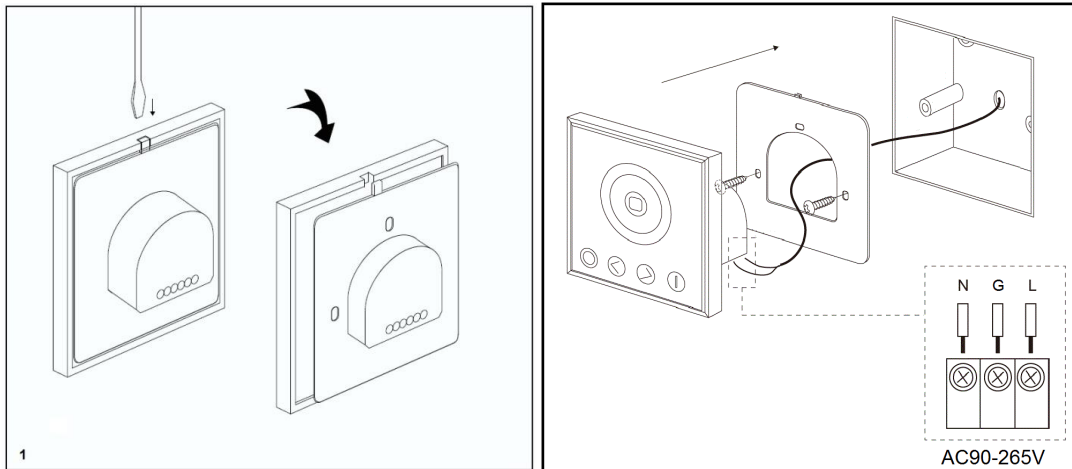

IV.Wireless remote control code value setting method

The biggest advantage of this system is that it can not only solve the cabling problem in engineering wirelessly, but also realize a wired-like operation experience. In order to facilitate the early testing and debugging of the project, the factory status of the receiver is normally unpaired and each remote controller has a unique code value. The user should perform the matching work of the remote controller and the receiver during the installation of the project to avoid the mutual influence of the radio frequency remote control technology during the later use.

Please pay attention to the following 3 points before operation:

- 1) All equipments in the complete system after installation should have a unified and unique code value, so as to achieve the security and stability of the system.
- 2) The receiver can only store one code value and cannot be overwritten. Before learning the new code value, it is necessary to clear original code of the receiver(if has); the remote controller can only save one code value but can be overwritten and can also restore the factory settings. In order to facilitate the later maintenance, the three components that may be involved in the system (including receivers, handheld remote controls, and panel remote controls) can realize mutual learning of code values.
- 3) Since the receiver performs code value learning in the power-on state, in order to avoid confusion in the area, it is recommended that each area has an independent power switch so that the power of other areas can be easily cut off when the code is being operated.

(1) Code pairing operation: means that the receiver will only be controlled by the value code remote control.

Step	Operation	Instructions
1	Connecting the load to the receiver and power on it.	1.It is necessary to clear the code first, if the receiver was coded before. 2.Batch operation can be performed within the remote control range. 3. Please remember to cut off other un-code zones power, or will be paired together.
2	Press and hold "ON" on the remote control for 5 seconds, the indicator of the remote control will flash quickly, means it enters the pairing code transmission status.	Will automatically exit code transmission status after 60 seconds, or pressing any key to exit.
3	See the load light flashes 3 times and return to the initial state	Pairing coding is finished successfully

(2) Code clearing operation: means that the original code value of the receiver will be cleared and returned to the factory state. Then it can be controlled by any compatible remote control, and can learn to a new code.

Step	Operation	Instructions
1	Connecting the load to the receiver and power on it.	1. The clearing operation should be finished within 5 minutes after the receiver is powered on. If exceeds the time, can be powered on again. 2. Batch operation can be performed within the remote control range.
2	Press and hold the remote control "OFF" for 10 seconds. The indicator of the remote control flashes quickly, means it enters the clearing code transmission status. There is no need to select the corresponding area when clearing code.	1. Will automatically exit code transmission status after 60 seconds, or pressing any key to exit. 2. If the original remote controller is lost, the new remote controller can be used for clearing operations.
3	See the load light flashes 3 times and return to the initial state	Clearing coding is finished successfully

(3) Code learning operation between remote controls: Used to unify system code values or copy a new remote controls.

Since each remote control has its own unique code at the time of delivery, when there are multiple remote controls in one system, one of them (for example, remote control A) must be selected as the system code value, and the code value of the rest remote controls (for example, remote control B) should be copied to the same one.

Step	Operation	Instructions
1	A remote control : Press and hold "ON" on the remote control for 5 seconds, the indicator of the remote control will flash quickly, means it enters the pairing code transmission status.	Will automatically exit code transmission status after 60 seconds, or pressing any key to exit.
2	B remote control: long press "MODE" for 5 seconds, the remote indicator light changes from 100% light to off light, means entering the code value receiving state	Will automatically exit the code value receiving state after 30 seconds, or exit after learning the code value successfully.
3	see the B remote control indicator light flash 3 times	Code copying is finished and exit code value receiving status.

(4) Copying code from receiver to remote control.

There is also available to copy the code from original receivers to new remote.

Step	Operation	Instructions
1	Cut off the power of receiver	Which one will be controlled by remote
2	Long-press "MODE" for 5 seconds, the remote indicator light changes from 100% light to off light, means entering the code value receiving state	Will automatically exit the code value receiving state after 30 seconds, or exit after learning the code value successfully.
3	Power on the receiver, will see remote control indicator light flash 3 times	Code copying is finished and exit code value receiving status.

*The distance from remote to receiver should be less than 2 meters.

(5) The remote control restores the factory setting: it means that the remote control will be restored to the factory's unique code value.

Step	Operation	Instructions
1	Long press "MODE " for 20 seconds	The remote indicator light down to off and then back to 100% light. Means this step is finished.
2	Press "OFF" to confirm the operation, the remote indicator flashes 3 times	Restore factory settings successfully.